

pilot bore	max. bore	chain pitch	max. width	a	b	c	d
8	16	9.525	24	45	25	64.9	30
9	22	12.7	33.1	61	35	79.4	36
9	28	12.7	33.1	69	43	79.4	36
13	32	12.7	33.1	77	50	87.4	40
13	35	15.875	41	86	53	99.7	45
13	40	15.875	41	96	60	99.7	45
13	45	15.875	41	107	70	99.7	45
18	56	19.05	51.1	128	85	123.5	56
18	71	19.05	51.1	152	110	123.5	56
23	80	25.4	65.3	170	115	141.2	63
28	100	25.4	65.3	203	140	157.2	71
33	110	31.75	81.9	233	160	178.8	80
43	125	38.1	102.7	256	170	202.7	90
53	140	38.1	102.7	304	210	222.7	100
58	160	50.8	131.7	341	224	254.1	112
73	200	50.8	131.7	405	280	310.1	140
85	205	63.5	160.6	426	294	519.5	241
95	260	63.5	160.6	507	374	519.5	241
117	310	76.2	197.3	608	420	751.1	353
147	380	76.2	197.3	705	520	751.1	353
197	430	101.6	263	806	570	860.1	400
247	470	127	332.3	932	640	1099.6	512
297	590	127	332.3	1093	800	1099.6	512
347	700	127	332.3	1255	960	1099.6	512

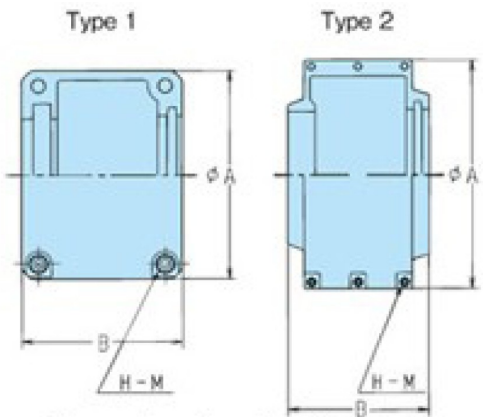

Place orders of casing with the casing model numbers specified.

A

59

75

84

92

101

111

122

142

167

186

220

250

307

357

406

472

496

578